

# DI14E



Product Family	Refrigerator
Installation	Built-in
Category	Top Mount
Built-in niche	144
Reference width	Until 60
Reference height	100 - 160
Cooling type	Static
Defrost	Manual
Hinge type	Sliding
Hinge position	Right
Reversible door	Yes
EAN code	8017709337742



## Aesthetics

Aesthetics	Universal	Side material	Steel
Colour	White	Side colour	White
Design	Flat	Logo	Silk screen
Material	Metal sheet	Door shelves profile colour	White
Handle type	Fixed	Drawers profile colour	White
Logo colour	Black	Colour of glass shelf profile	White

## Refrigerator compartment features



No. of adjustable shelves	3	Crisper Cover	Yes
Number of fruit and vegetables drawers	1	Type of crisper/vegetable drawers cover	Glass
Type of adjustable shelves	Glass	Internal light in fridge	Yes
Type of crisper/vegetable drawers cover	Standard	Type of internal light (fridge)	LED

## Refrigerator Inner Door

Number of adjustable door shelves	2	No. of bottle shelves	1
-----------------------------------	---	-----------------------	---

## Freezer compartment features

No. of shelves	1	Type of shelves	Wire
----------------	---	-----------------	------

## Other Freezer features

Accessories	1 ice box
-------------	-----------

## Other technical features

Type of temperature control	Electro-mechanical
No. of compressors	1
Refrigerant gas type	R600a
Type of compressor	Standard
Foam agent	Cyclopentane

## Performance / Energy Label NEW

			
Annual energy consumption	178 kWh/year	Noise level	37 dB(A) re 1pW
Energy efficiency class	E	Thaw time	11.33 h
Airborne acoustical noise emission class	C	4 star - Freezing capacity	2.6 Kg/24h
Total volume	209 l	Climatic class	N
Sum of the volumes of the frozen compartment(s)	38 l	EI	100 %
Sum of the volumes of the chill compartment(s) and the unfrozen compartment(s)	172 l		

## Electrical Connection

Plug	(F;E) Schuko	Frequency (Hz)	50 Hz
Current	0,51 A	Power supply cable length	120 cm
Voltage (V)	220-240 V		

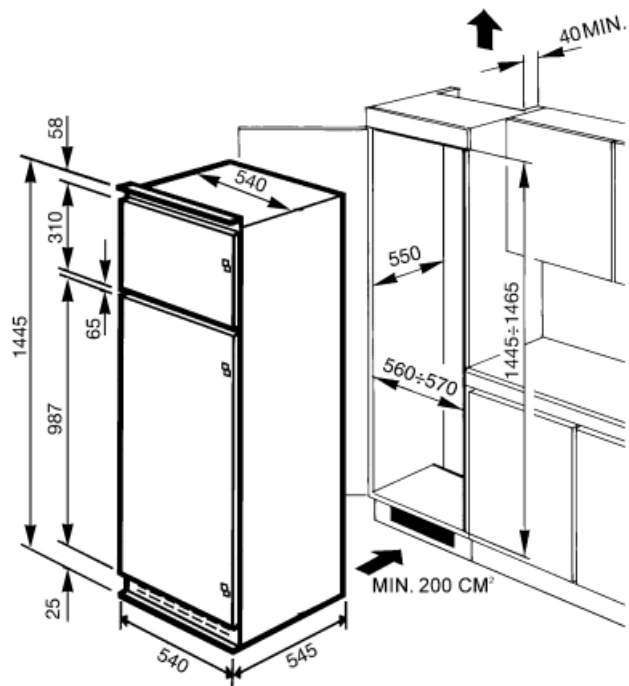

## Symbols glossary

---

-  Energy efficiency class E
-  LED interior lighting: is a more energy efficient and long lasting way of illuminating the interior of the appliance.
-  Built-in niche