

# KDH12WLD



Product family	Hood
Hood Type	DownDraft
Design	Fully integrated
Extraction	Extraction
Electronic control	Yes
Perimeter extraction	Yes
Material	Glass
EAN code	8017709277826
Hood width	12 cm



## Aesthetics

Aesthetic	Universale	Glass Type	ceramic Eclipse
Colour	Black	Serigraphy colour	White
Finishing	Glass	Logo	Silk screen

## Controls



Control setting	Touch control	Display	Digital
Led color	Ice		

## Programme / Functions

No. of speeds	3
Intensive speed	
Time-setting options	

## Technical Features



Free outlet maximum capacity	570 m <sup>3</sup> /h	Anti-grease filters	Stainless steel
Motor power	145 W	Filter replacement indicator	Yes
No. of filters	1		

	Extraction rate IEC 61591 [m <sup>3</sup> /h]	Noise level IEC 60704-2-13 [dB(A)]
Speed 1	370	62
Speed 2	420	66
Speed 3	470	69
Intensive speed	550	72

## Accessories Included

Sliding door Yes

## Performance / Energy Label

A<sup>+</sup>

Annual Efficiency Consumption (AEChood)	37 kWh/a	Airbourne acoustical A-weighted sound Power Emission at minimum speed (SPEmin)	62 dB(A)
Energy efficiency class (EEC)	A+	Airborne acoustical A-weighted sound Power Emission at maximum speed (SPEmax)	69 dB(A)
Fluid Dynamic Efficiency (FDE)	32	Airbourne acoustical A-weighted sound power emission at boost speed (SPEboost)	72 dB(A)
Fluid Dynamic Efficiency class (FDEC)	A	Power Consumption in Off mode (Po)	0.49 W
Lighting Efficiency Class (LEC)	NA	Time increase factor (F)	0.8
Grease Filtering Efficiency (GFE)	75.1 %	Energy Efficiency Index	43.4
Grease Filtering Efficiency Class (GFEC)	C	Measured air flow rate at best efficiency point (Qbep)	295 m <sup>3</sup> /h
Air flow at minumum speed (Qmin)	370 m <sup>3</sup> /h	Measured air pressure at best efficiency point (Pbep)	490 Pa
Air flow at maximum speed (Qmax)	470 m <sup>3</sup> /h	Measured electric power input at best efficiency point (Wbep)	125 W
Air flow at boost speed (Qboost)	550 m <sup>3</sup> /h	Sound power level at highest setting (Lwa)	72 dB(A)

## Electrical Connection

Electrical connection rating	145 W	Frequency (Hz)	50-60 Hz
Voltage	220-240 V	Power supply cable length	1500 mm

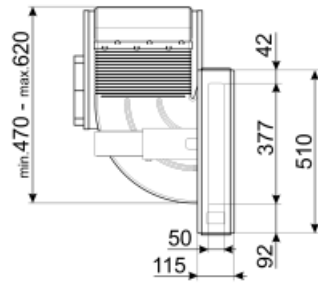
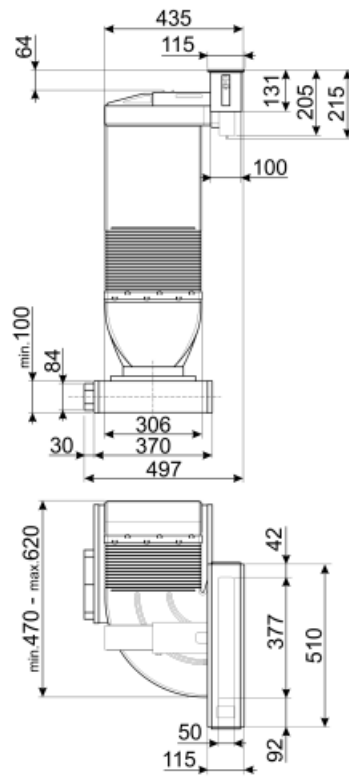
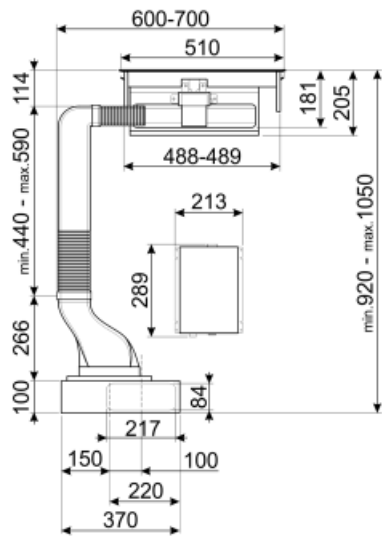

## Not included accessories

---

### CFKDH12STD

Charcoal filter for hob aspiration hood  
Kit 1 piece



### CFKDH12HP

Ceramic filter for Domino Hood  
KDH12WLD Kit 1 piece High  
performances. Regenerable into oven  
Magnetic Metallic grid included.



### FLMSTPKDH12

Metallic FLAME FRANGES hob  
aspiration hood Kit 1 piece



### GRIDKDH12







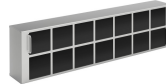

Metallic grid for standard charcoal  
filter hob aspiration hood Kit 1 piece

### FLTKDH

Anti-Odour Filter Ceramic regenerable  
suitable for Recirculating kit  
(accessory CFKDH12HP)



## Symbols glossary (TT)

- |  |  |   |  |
|--|--|---|--|
|  | Filters: Model has filters to help remove grease from the steam emanating from the pans during cooking.  |  | Switch off automatically: A special setting, to run after the end of cooking for a pre-set time and then switch off automatically. |
|  | A+: Energy efficiency class A+ helps to save up to 10% energy compared to class A. Maximum performance with minimum consumption is guaranteed. |  | Electronic display: to give a visual reminder of the options selected.   |
|  | Warning light(s): to advise when filters need changing.  |  | Perimeter extraction panels: very efficient and aid noise reduction.   |
|  | Touch controls: Easy to use touch controls allow the appliance to be programmed at the touch of a button.                                      |  | Intensive/turbo setting: when extra fast extraction is required.   |