

# CPR915X

Product Family	Drawer
Commercial height	15 cm
Type	Reheat



## Aesthetics

Aesthetic Colour Finishing Material	Victoria Stainless steel Fingerproof Stainless steel	Type of steel Logo Logo position	Brushed Silk screen Inside
-------------------------------------	---	--	----------------------------------

## Controls

Type of control setting	Control knobs	Control knobs	Standard
No. of controls	1	Controls colour	Steel effect

## Programme / Functions

Defrost	Yes
Proofing	Yes
Mug warmer	Yes
Keep warm	Yes
Dish warmer	Yes
Reheating	Yes

## Technical Features

Opening mechanism	Push-pull	Capacity	21 l
Base material	Stainless steel	Type of heating	Fan assisted
Max weight allowance	15 kg	Accessories included	Silicone antislip mat
Maximum drawer loading weight	85 kg		

## Electrical Connection

Plug	(F;E) Schuko	Voltage (V)	220-240 V
Nominal power	400 W	Frequency (Hz)	50-60 Hz
Current	2 A		

## Logistic Information

Width (mm)	597 mm	Product Height (mm)	135 mm
Depth (mm)	538 mm		

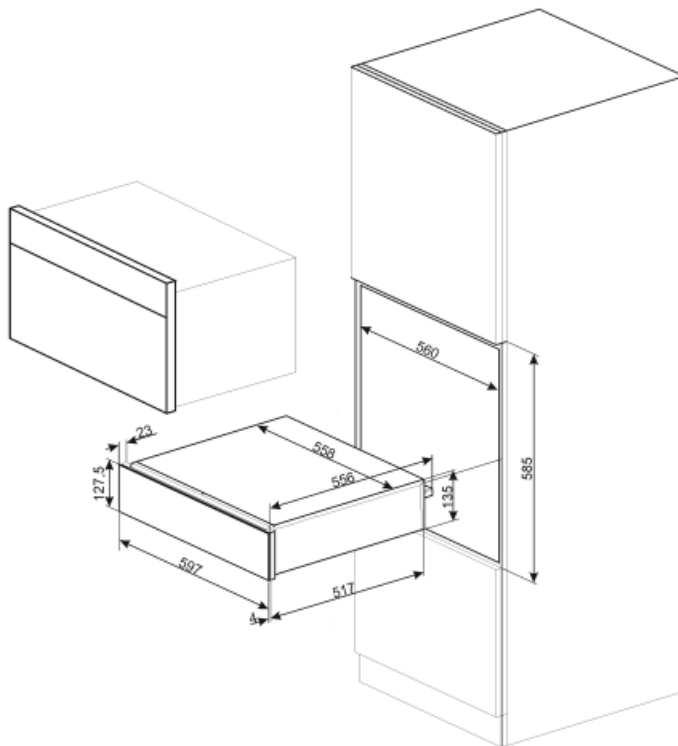

## Not included accessories

---

### KITCABLE90UK

Cable with IEC connector and UK plug