

FC20XDNE



| | |
|-----------------|----------------|
| Product Family | Refrigerator |
| Installation | Free standing |
| Category | Bottom Mount |
| Reference width | Until 60 |
| Cooling type | Total No Frost |
| Defrost | Automatic |
| Hinge type | Standard |
| Hinge position | Right |
| Reversible door | Yes |
| EAN code | 8017709299866 |



Aesthetics



| | | | |
|-------------|--------------|------------------|--------------------|
| Aesthetic | Universale | Side material | Steel |
| Colour | Inox-look | Side colour | Silver |
| Material | Steel Effect | Logo | Applied |
| Handle | Integrated | Display | LED |
| Handle type | Fixed | Display position | Esterno (su porta) |
| Logo colour | Chrome | | |

Refrigerator compartment features



| | | | |
|---|------------------|---|-------|
| No. of adjustable shelves | 3 | Bottle shelf | Yes |
| Number of fruit and vegetables drawers | 1 | Type of crisper/vegetable drawers cover | Glass |
| Type of adjustable shelves | Glass | Low temperature compartment | Yes |
| Type of crisper/vegetable drawers cover | On sliding rails | Internal light in fridge | Yes |
| Crisper Cover | Yes | Type of internal light (fridge) | LED |

Refrigerator Inner Door

| | | | |
|-----------------------------------|---|-----------------------|---|
| Number of adjustable door shelves | 3 | No. of bottle shelves | 1 |
|-----------------------------------|---|-----------------------|---|

Other Refrigerator features



Accessories Bottle holder, Egg tray **MultiFlow** Yes

Freezer compartment features

Number of drawers 3

Other Freezer features

Accessories 1 ice box

Other technical features



| | |
|-----------------------------|--------------------|
| Functions display | Fast freezing, ECO |
| Door open alarm | Yes |
| Temperature Alarm | Yes |
| Type of temperature control | Electronic |
| No. of compressors | 1 |
| Refrigerant gas type | R600a |
| Type of compressor | Standard |
| Refrigerant Quantity (gr) | 38 g |
| Foam agent | Cyclopentane |

Performance / Energy Label NEW 2019









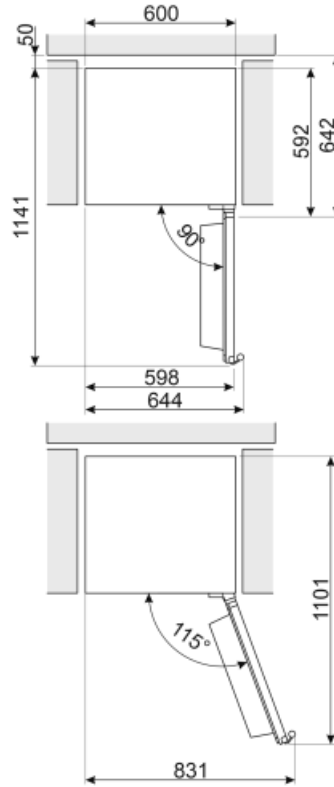
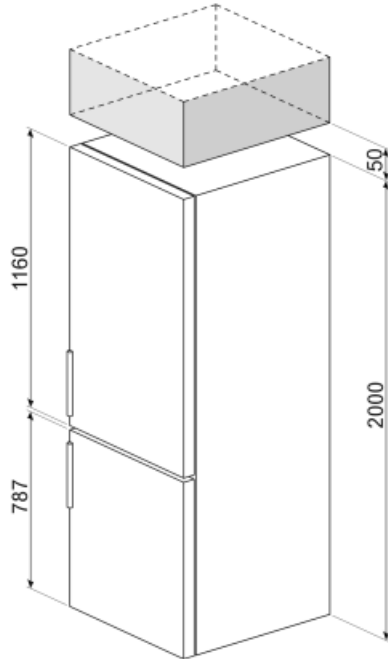

| | | | |
|--|-----------|-------------------------------------|-----------------|
| Annual energy consumption | 246 kWh/a | Airborne acoustical noise emissions | 38 dB(A) re 1pW |
| Energy efficiency class | E | Temperature Rise Time | 10 h |
| Airborne acoustical noise emission class | C | 4 star - Freezing capacity | 9.0 Kg/24h |
| Total net volume | 331 l | Climate class | SN, N, ST, T |
| Sum of the volumes of the frozen compartment(s) | 96 l | EEl | 100 % |
| Sum of the volumes of the chill compartment(s) and the unfrozen compartment(s) | 235 l | | |

Electrical Connection

| | | | |
|-------------------------------------|--------------|----------------------------------|-----------|
| Plug | (F;E) Schuko | Voltage (V) | 220-240 V |
| Electrical connection rating | 70 W | Frequency (Hz) | 50 Hz |
| Current | 10 A | Power supply cable length | 200 cm |



Symbols glossary (TT)

- | | | | |
|--|--|---|--|
|  | 4 stars freezing compartment for better food preservation. |  | A++: Energy efficiency class A++ helps to save up to 20% energy compared to class A. Maximum performance with minimum consumption is guaranteed. |
|  | The automatic defrost system works by automatically defrosting at regular intervals eliminating the need to defrost altogether. |  | LED display: to show programmes, functions and options selected and the time to the end of the cycle. |
|  | Economical mode: Analyzes fridge functioning during the activation and optimizes the operating cycle in order to reduce power consumption. |  | Fast freezing: The fast freezing function brings the temperature of the compartment down when activated a few hours prior to usage. |
|  | LED interior lighting: is a more energy efficient and long lasting way of illuminating the interior of the appliance. |  | Air plus: keeps food fresher for longer. |
|  | Energy efficiency class E | | |