

C8174TNE



Product Family	Refrigerator
Installation	Built-in
Category	Bottom Mount
Built-in niche	178
Reference width	Until 60
Reference height	160 - 200
Sistema Total No - Frost	Total
Cooling type	Total No Frost - Double Cooling system
Defrost	Automatic
Hinge type	Sliding
Hinge position	Right
Reversible door	Yes
EAN code	8017709293406



Aesthetics



Aesthetic	Universale	Door shelves profile color	Silver
Colour	White	Drawers profile color	Silver
Material	Metal sheet	Color of glass shelf profile	Chrome
Side material	Steel	Display	LCD Touch
Side colour	White	Display position	Interno (sul Top)

Refrigerator compartment features



No. of adjustable shelves	2	Bottle shelf	Yes
Number of fruit and vegetables drawers	1	Type of crisper/vegetable drawers cover	Glass
Type of adjustable shelves	Glass	Life Plus zone-0°C	Yes
Type of crisper/vegetable drawers cover	Standard	Internal light in fridge	Yes
Crisper Cover	Yes	Type of internal light (fridge)	LED

Refrigerator Inner Door

Number of adjustable door shelves	2	No. of bottle shelves	1
--	---	------------------------------	---

Other Refrigerator features



Accessories	Egg tray	Fan	Yes
MultiFlow	Yes		

Freezer compartment features

Number of drawers	3	No. of shelves	2
-------------------	---	----------------	---

Other Freezer features



Accessories	1 ice box	Fast freezing compartment	Yes
-------------	-----------	---------------------------	-----

Other technical features



Functions display	Holiday, Fast freezing, Fast cooling, Temperature alarm
Door open alarm	Yes
Temperature Alarm	Yes
Type of temperature control	Electronic
No. of compressors	1
Refrigerant gas type	R600a
Type of compressor	Inverter
Foam agent	Cyclopentane

Performance / Energy Label NEW 2019









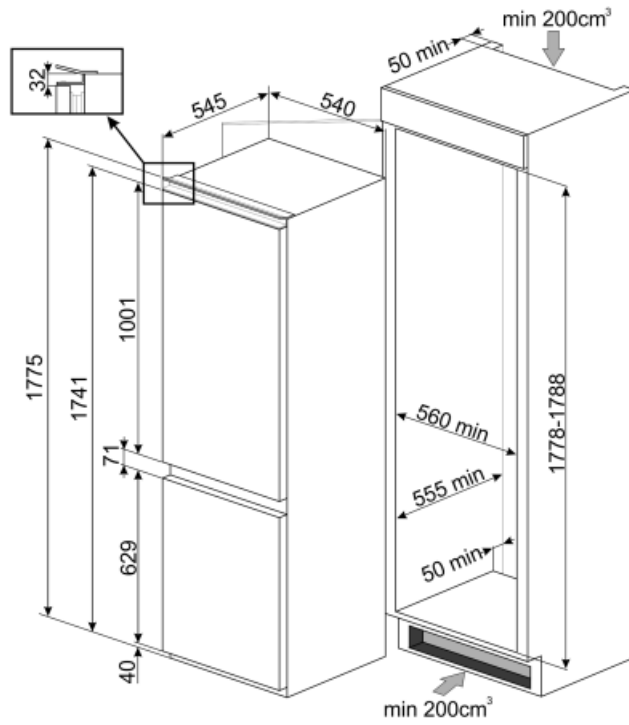





Annual energy consumption	224 kWh/a	Airborne acoustical noise emissions	38 dB(A) re 1pW
Energy efficiency class	E	Temperature Rise Time	13 h
Airborne acoustical noise emission class	C	4 star - Freezing capacity	3.2 Kg/24h
Total net volume	254 l	Climate class	SN, T
Sum of the volumes of the frozen compartment(s)	69 l	EEl	99 %
Sum of the volumes of the chill compartment(s) and the unfrozen compartment(s)	185 l		

Electrical Connection

Plug	(F;E) Schuko	Voltage (V)	220-240 V
Electrical connection rating	125 W	Frequency (Hz)	50 Hz
Current	0.8 A	Power supply cable length	150 cm



Symbols glossary (TT)

	4 stars freezing compartment for better food preservation.		The automatic defrost system works by automatically defrosting at regular intervals eliminating the need to defrost altogether.
	LCD display: to optimize performance and simplify the use of the appliance.		Energy efficiency class E
	A++: Energy efficiency class A++ helps to save up to 20% energy compared to class A. Maximum performance with minimum consumption is guaranteed.		Ventilated: Forced distribution of cold air in the refrigerator compartment, which allows even temperature distribution within the fridge.
	Fast freezing: The fast freezing function brings the temperature of the compartment down when activated a few hours prior to usage.		Power saving mode: The power saving mode allows you to disable the refrigerator and keep the freezer working.
	LED interior lighting: is a more energy efficient and long lasting way of illuminating the interior of the appliance.		Life Plus 0°C: The temperature in the Lifeplus compartments is kept at 0°C, which preserves fresh meat and fish longer.
	Smeg's evolution towards more intelligent and eco-friendly models has led to the choice of Inverter technology, which significantly reduces consumption.		Air plus: keeps food fresher for longer.
	Built-in niche		