

# C8175TNE

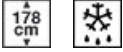

<b>Product Family</b>	Refrigerator
<b>Installation</b>	Built-in
<b>Category</b>	Bottom Mount
<b>Built-in niche</b>	178
<b>Reference width</b>	Until 60
<b>Reference height</b>	160 - 200
<b>Sistema Total No - Frost</b>	Total
<b>Cooling type</b>	Total No Frost - Double Cooling system
<b>Defrost</b>	Automatic
<b>Hinge type</b>	Sliding
<b>Hinge position</b>	Right
<b>Reversible door</b>	Yes
<b>EAN code</b>	8017709293420



## Aesthetics



<b>Aesthetic</b>	Universale	<b>Logo</b>	Silk screen
<b>Colour</b>	White	<b>Door shelves profile color</b>	Silver
<b>Material</b>	Metal sheet	<b>Drawers profile color</b>	Silver
<b>Logo colour</b>	Silver	<b>Color of glass shelf profile</b>	Chrome
<b>Side material</b>	Steel	<b>Display</b>	LCD Touch
<b>Side colour</b>	White	<b>Display position</b>	Interno (sul Top)

## Refrigerator compartment features

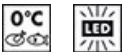

<b>No. of adjustable shelves</b>	2	<b>Bottle shelf</b>	Yes
<b>Number of fruit and vegetables drawers</b>	1	<b>Type of crisper/vegetable drawers cover</b>	Glass
<b>Type of adjustable shelves</b>	Glass	<b>Life Plus zone-0°C</b>	Yes
<b>Type of crisper/vegetable drawers cover</b>	Standard	<b>Internal light in fridge</b>	Yes
<b>Crisper Cover</b>	Yes	<b>Type of internal light (fridge)</b>	LED

## Refrigerator Inner Door

<b>No. of bottle shelves</b>	1
------------------------------	---

Number of adjustable door shelves 2

## Other Refrigerator features



Accessories  
MultiFlow

Egg tray  
Yes

Fan

Yes

## Freezer compartment features

Number of drawers 3

No. of shelves 2

## Other Freezer features



Accessories

1 ice box

Fast freezing  
compartment

Yes

## Other technical features



Functions display

Holiday, Fast freezing, Fast cooling, Temperature alarm

Door open alarm

Yes

Temperature Alarm

Yes

Type of temperature control

Electronic

No. of compressors

1

Refrigerant gas type

R600a

Type of compressor

Inverter

Refrigerant Quantity (gr)

44 g

Foam agent

Cyclopentane

## Performance / Energy Label NEW 2019



Annual energy consumption 224 kWh/a

Airborne acoustical noise emissions 38 dB(A) re 1pW

Energy efficiency class E

Temperature Rise Time 13 h

Airborne acoustical noise emission class C

4 star - Freezing capacity 3.2 Kg/24h

Total net volume 254 l

Climate class SN, T

Sum of the volumes of the frozen compartment(s) 69 l

EEl 99 %







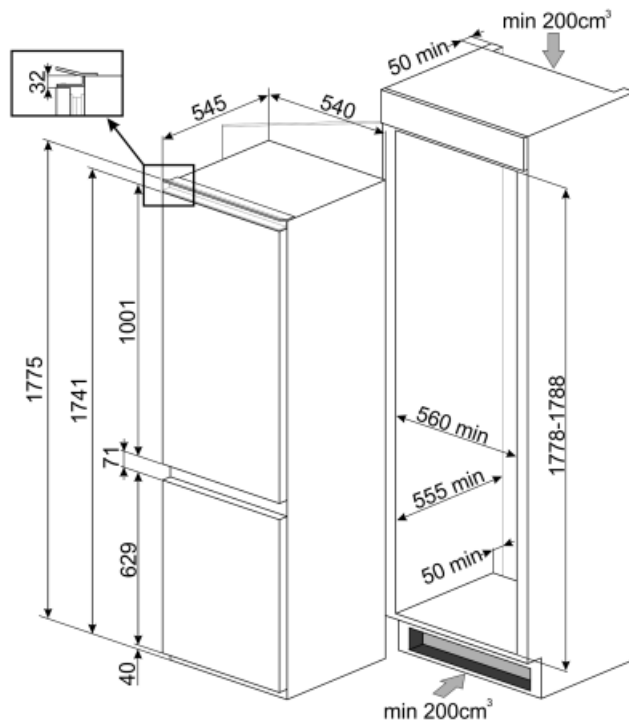





Sum of the volumes of the chill compartment(s) and the unfrozen compartment(s) 185 l

## Electrical Connection

Plug	(F;E) Schuko	Voltage (V)	220-240 V
Electrical connection rating	125 W	Frequency (Hz)	50 Hz
Current	0,8 A	Power supply cable length	150 cm



## Symbols glossary (TT)

 <p>4 stars freezing compartment for better food preservation.</p>	 <p>The automatic defrost system works by automatically defrosting at regular intervals eliminating the need to defrost altogether.</p>
 <p>LCD display: to optimize performance and simplify the use of the appliance.</p>	 <p>Energy efficiency class E</p>
 <p>A++: Energy efficiency class A++ helps to save up to 20% energy compared to class A. Maximum performance with minimum consumption is guaranteed.</p>	 <p>Ventilated: Forced distribution of cold air in the refrigerator compartment, which allows even temperature distribution within the fridge.</p>
 <p>Fast freezing: The fast freezing function brings the temperature of the compartment down when activated a few hours prior to usage.</p>	 <p>Power saving mode: The power saving mode allows you to disable the refrigerator and keep the freezer working.</p>
 <p>LED interior lighting: is a more energy efficient and long lasting way of illuminating the interior of the appliance.</p>	 <p>Life Plus 0°C: The temperature in the Lifeplus compartments is kept at 0°C, which preserves fresh meat and fish longer.</p>
 <p>Smeg's evolution towards more intelligent and eco-friendly models has led to the choice of Inverter technology, which significantly reduces consumption.</p>	 <p>Air plus: keeps food fresher for longer.</p>
 <p>Built-in niche</p>	